

POSE²IDON: A New concept of the “Electric Ship”

Pierre MARCHAL

Extend the benefits of the electric ship concept to a wider range of vessels and obtain the following benefits:

Lower emissions

Reduction of the risk of incidents and accidents

Reduction of the costs and manpower effort for maintenance

- High Temperature Supraconducting (HTS) Electric Machines (motors and generators)
- DC Distribution System and HTS cabling
- Electric Auxiliaries
- Shore Supply for large vessels
- Wireless Control
- Arc Fault Protection System

- Market studies determining the possible extension of the electric ship concept
- Numeric simulations
- Evaluation of the benefits for 2 ship types
- Large scale demonstration on shore

POSE²IDON PARTNERS



POSE²IDON Organization

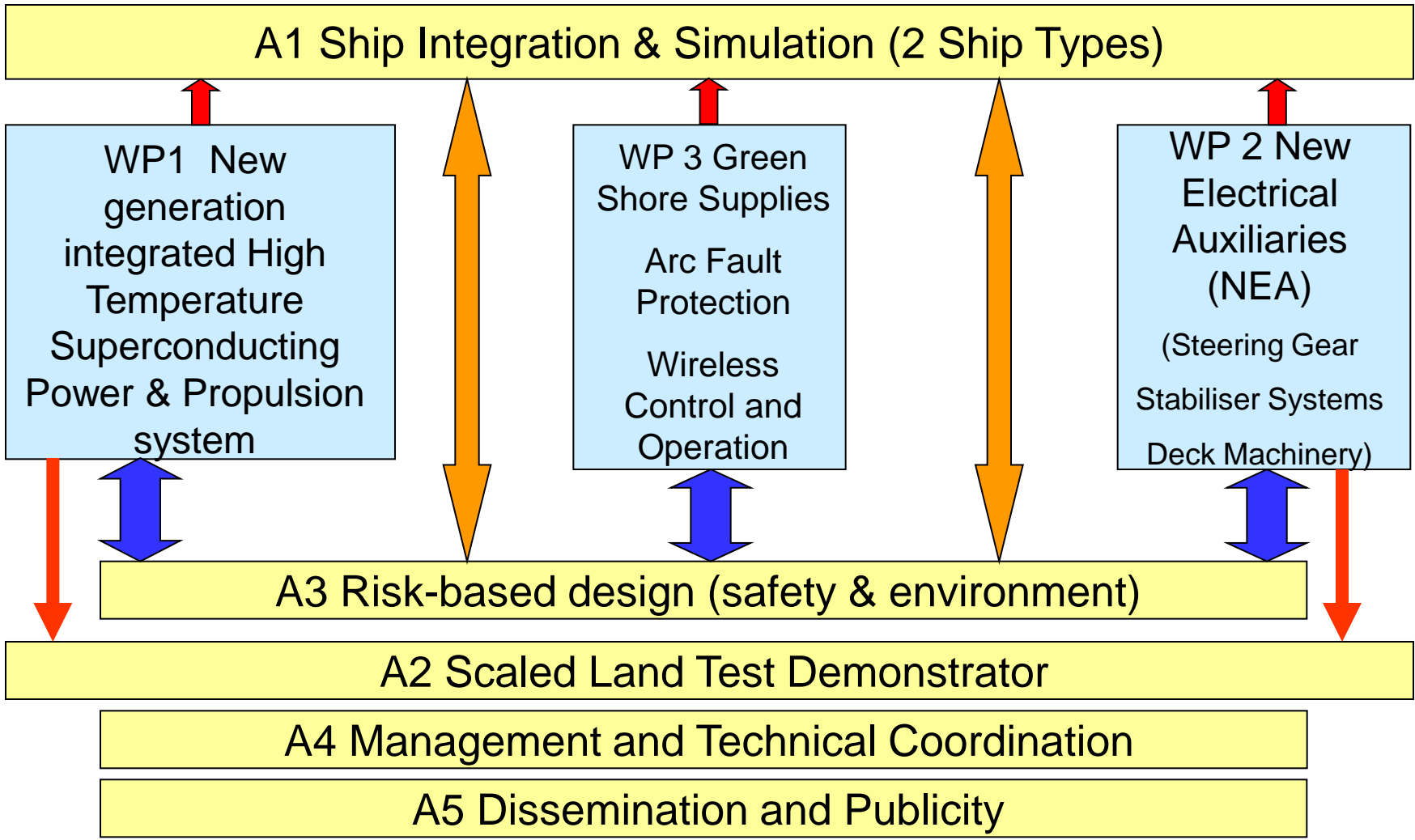

New Generation HTS Electrical Machines

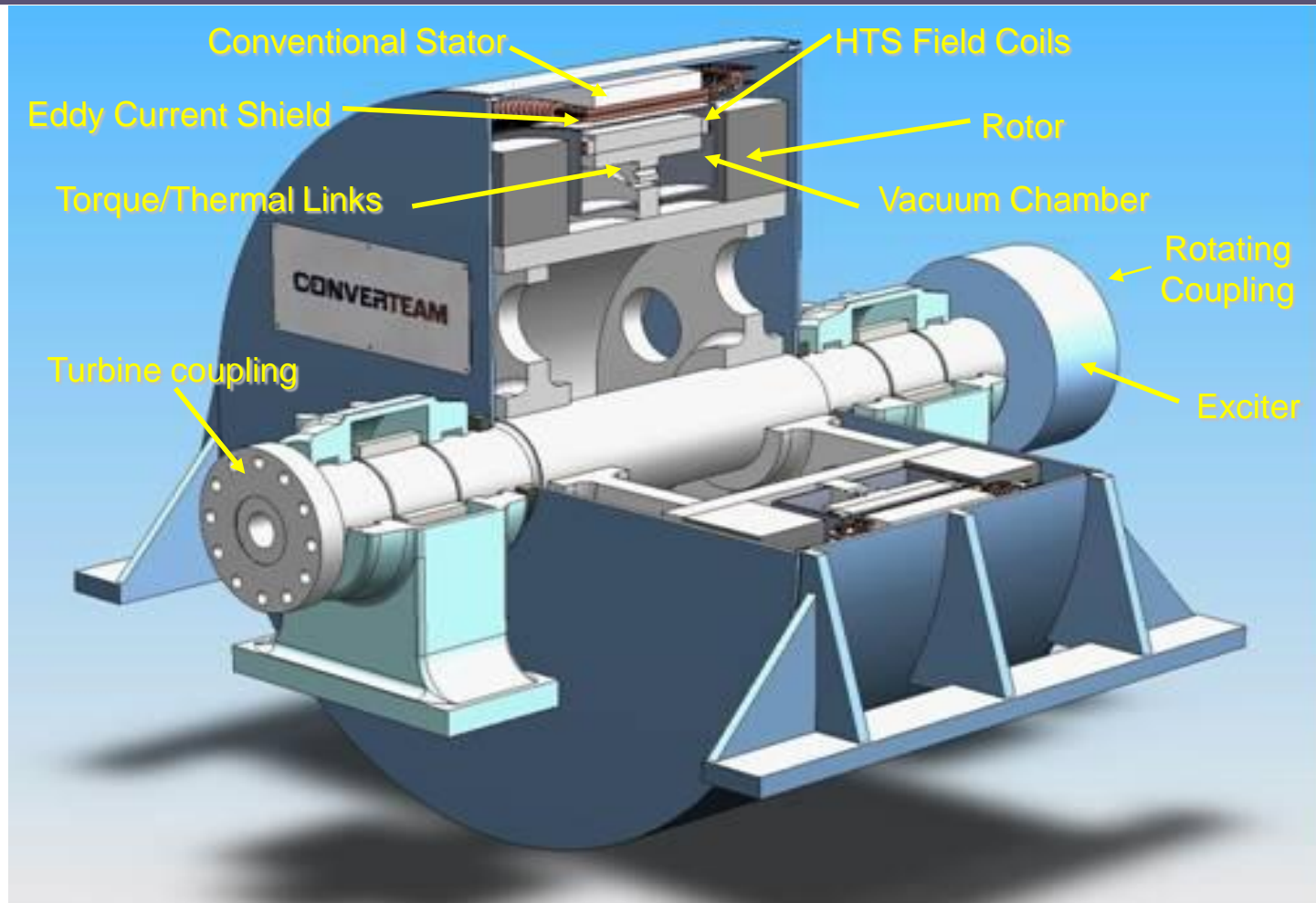

Rating: 1789kVA, 1700 kW, 5250V, 28 poles, 0.95 pf, 214 rpm

HTS Machines benefit

HTS Motor



- Efficiency = 98.6%
 - 43% of the loss in the conventional motor
- Smaller volume
 - 47% of the volume of the conventional motor

High Efficiency Conventional



- Efficiency = 96.8%
 - 230% of the loss in the HTS motor
 - Annual energy costs to operate may be \$50,000 more than HTS motor.
- Larger volume

The replacement hydraulic systems by NEA brings following benefits:

- Energy reduction by energy recovery and regeneration devices
- Reduced mass and size
- Reduction of the risk of fire or pollution
- Cost and manpower reduction for maintenance
- Simulation during the design phase of the complete electrical network and evaluation of its operational performance
- Lower emissions:
 - More Efficient
 - Lower noise generation
 - Increased reliability
 - Reduced operation costs

NEA - Steering Gear

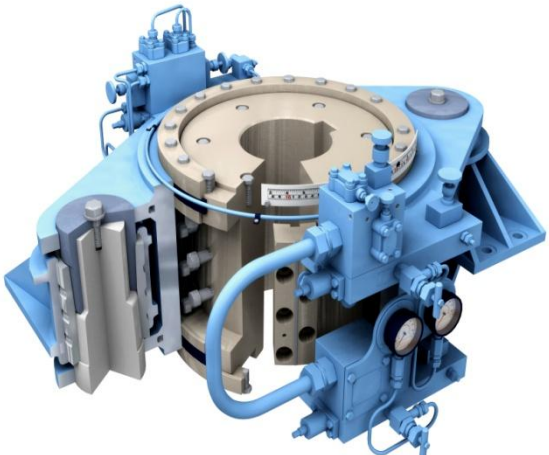
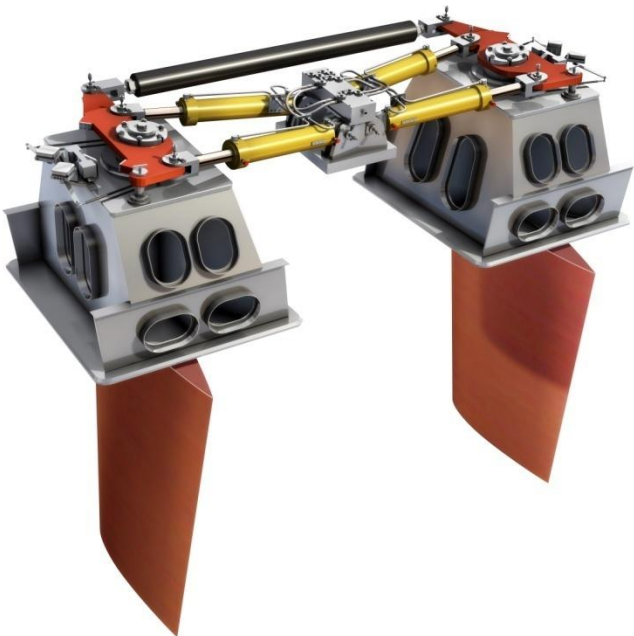
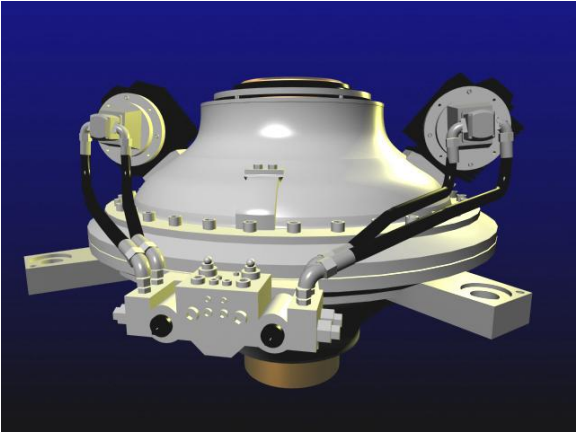

NEA – Fin stabilisers

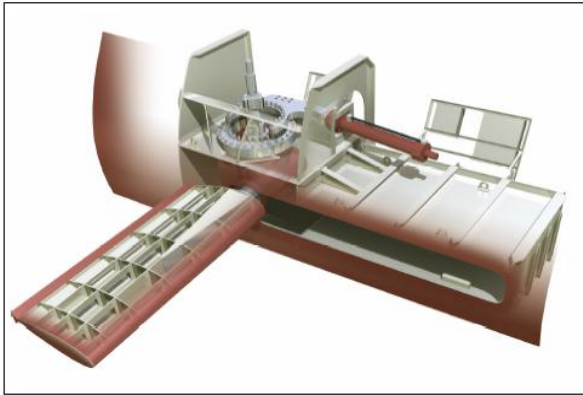
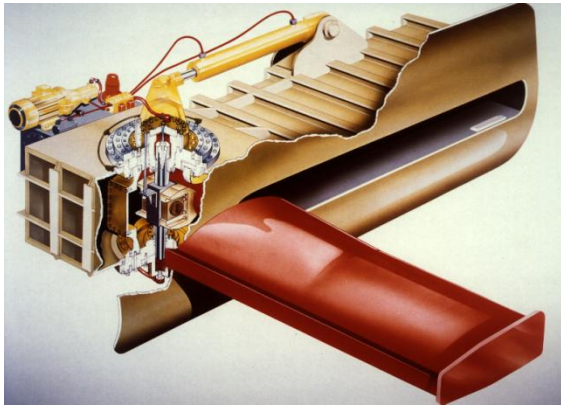

Brown Brothers Aquanus folding fin stabiliser

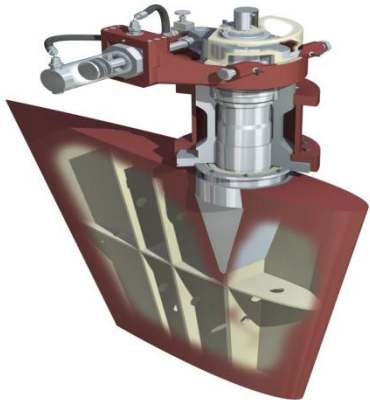

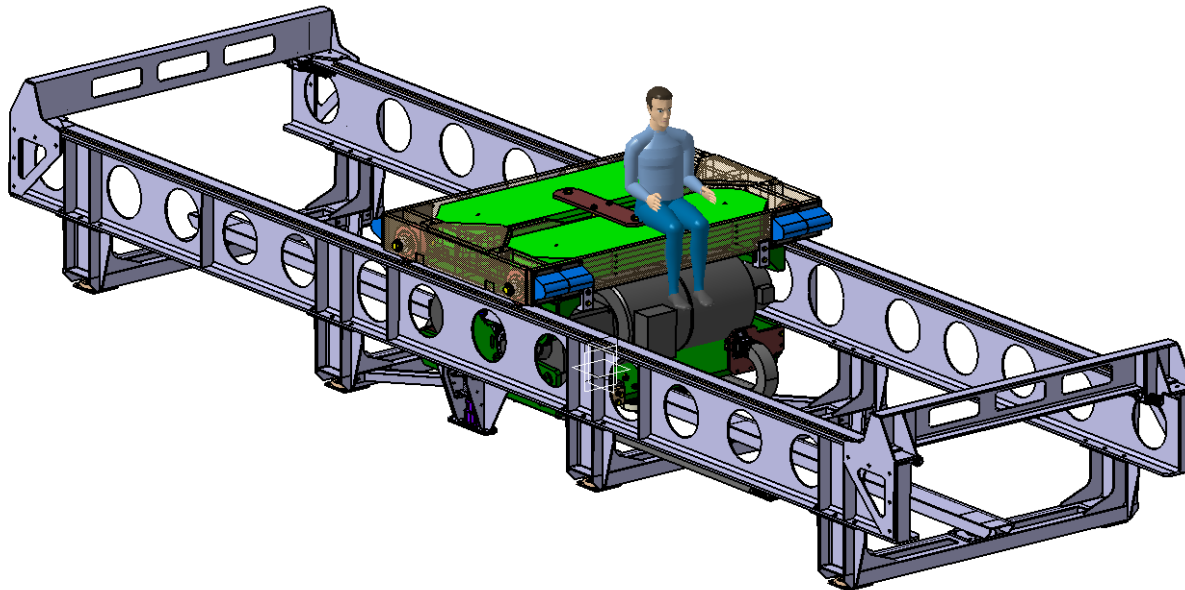

Prototype of a 40 tons mobile mass for a 2000 / 4000 T vessel

NEA - Deck Equipment



Green Shore Supplies

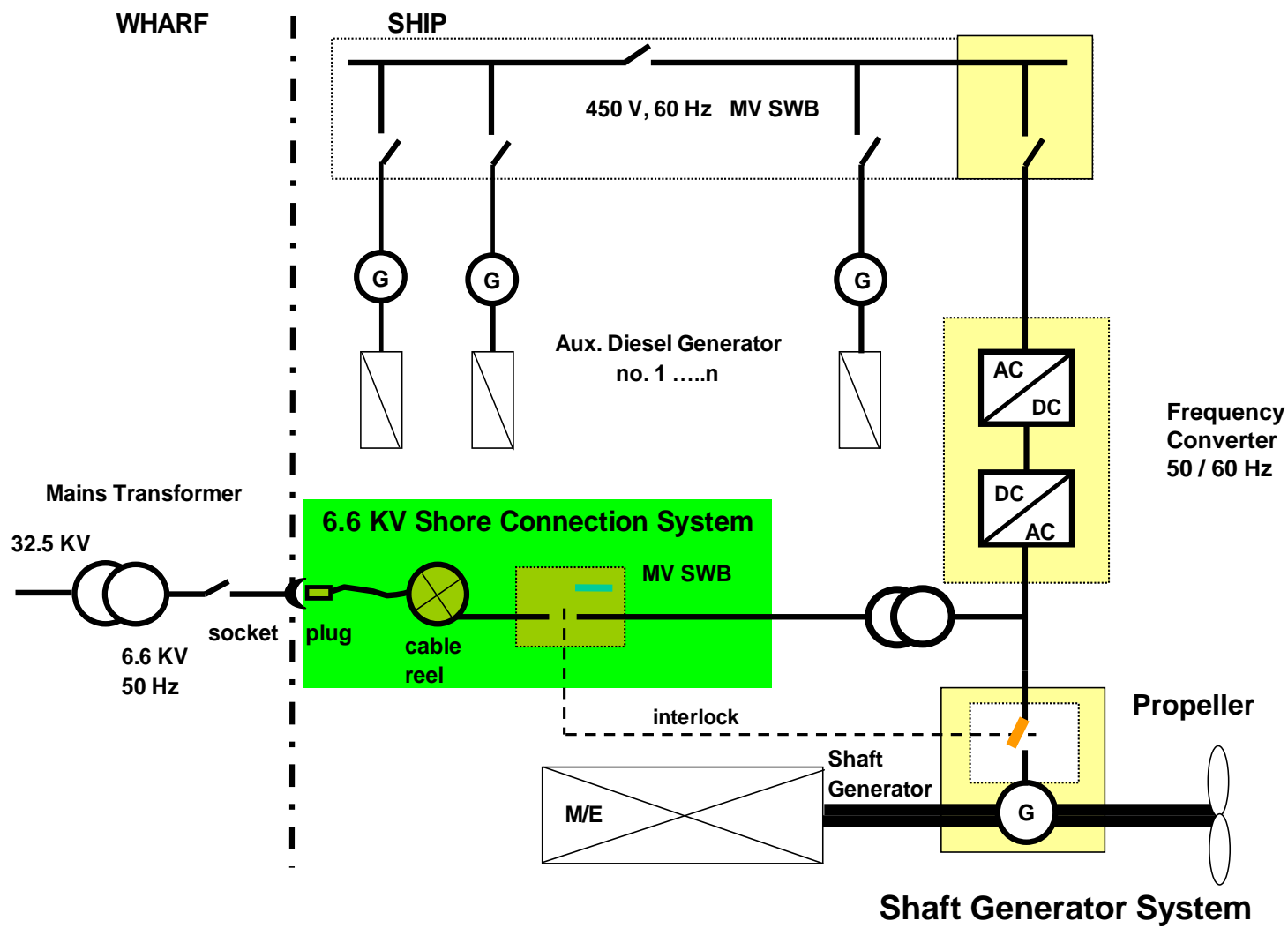



HV Plug

Socket station



- Minimised risk to personnel and equipment
- Rapid reaction time (2 - 5 ms)
- Restriction of arc energy below 100 kW
- Using of optical fibres as fast sensors of arc radiation
- Optimised to conditions on board
- Wide parameter region (low and medium power, AC& DC)

Arc Fault Protection



Arc fault in a distribution board without protection system

- Pose²idon Objectives:
 - Reduction of shipbuilding cost.
 - Reduction of energy consumption (Mass Reduction).
 - Easier ship refit.
 - Communication system more reliable due to removals of cables.

- The Pose²idon Solution:
 - Radio electrical propagation simulation tools:
 - Implement transmitters & receivers.
 - Influence the ship design.



Task 1:

Market Analysis of the electric ship concept

Task 2:

Selection of the ship type for evaluation

Task3:

Database

Task 4:

Simulation tools for ship systems integration

Task 5:

Detailed evaluation on 2 ship types et comparison with the existing

- Performance prediction
- Modelling and optimization
- Testing of final design
- Impact and economical study

Scaled Land Based Demonstrator

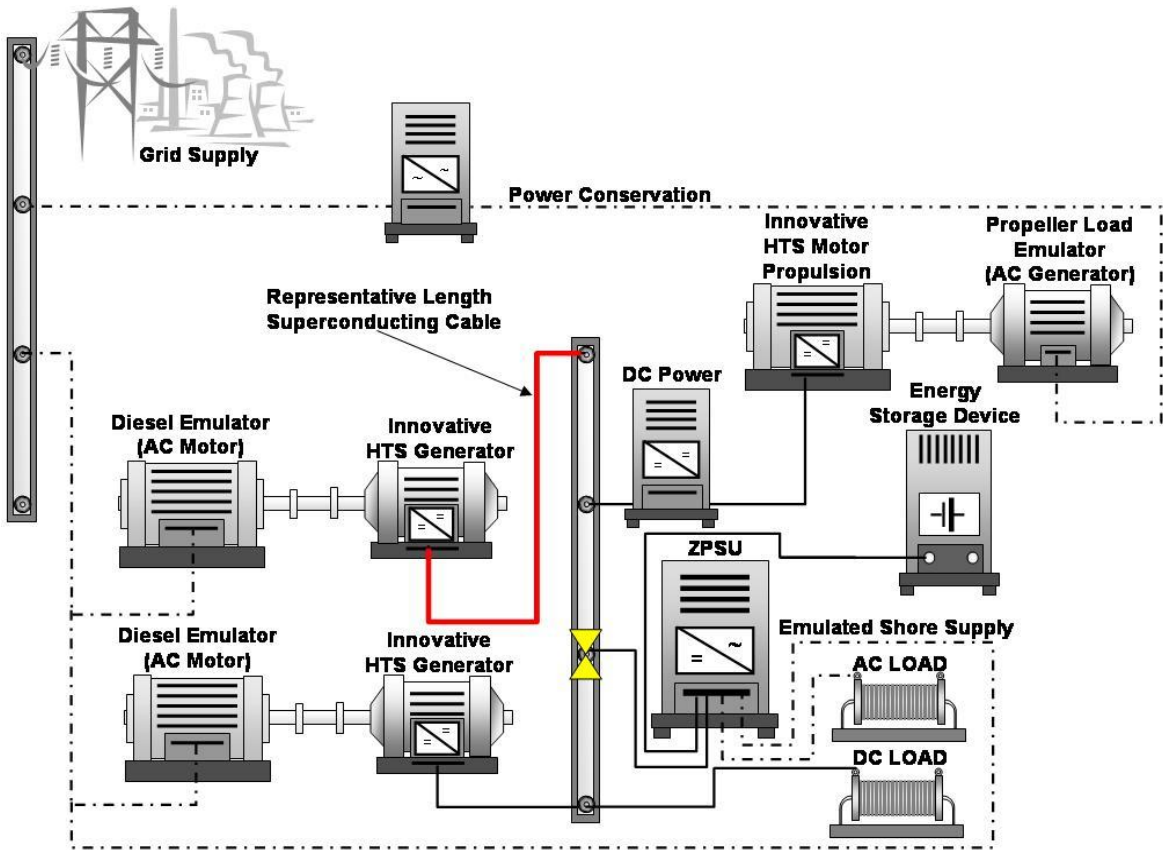

To ensure that the developed technology is

- cost effective,
- safe and environmentally friendly,
- in compliance with all relevant regulatory requirements.

HTS Technology

- 2d generation coils validation
- Performant cooling system and fluid validation
- Risk analysis
- Electric machines catalog
- DC network with associated electronic protection systems

Electric auxiliaries

- Numeric simulations
- Battery and inductance packs to be standardised

Ship integration

- Selection of the 2 ship types
- On-shore demonstrators

Web site www.poseidon-ip.eu

Newsletters

- N°1 Presentation of the project
- N°2 Market study – Wireless technology – Risk analysis
- N°3 New electrical auxiliaries

*To receive the newsletter , please contact:
marchal.pal@wanadoo.fr*

Final conference End 2012 on the ESTD facility in Wheastone

Contact Mr. Chris Trout - BMT Defence Services Ltd
Maritime House, 210 Lower Bristol Road,
Bath BA2 3DQ, United Kingdom
ctrout@bmtdsl.co.uk